

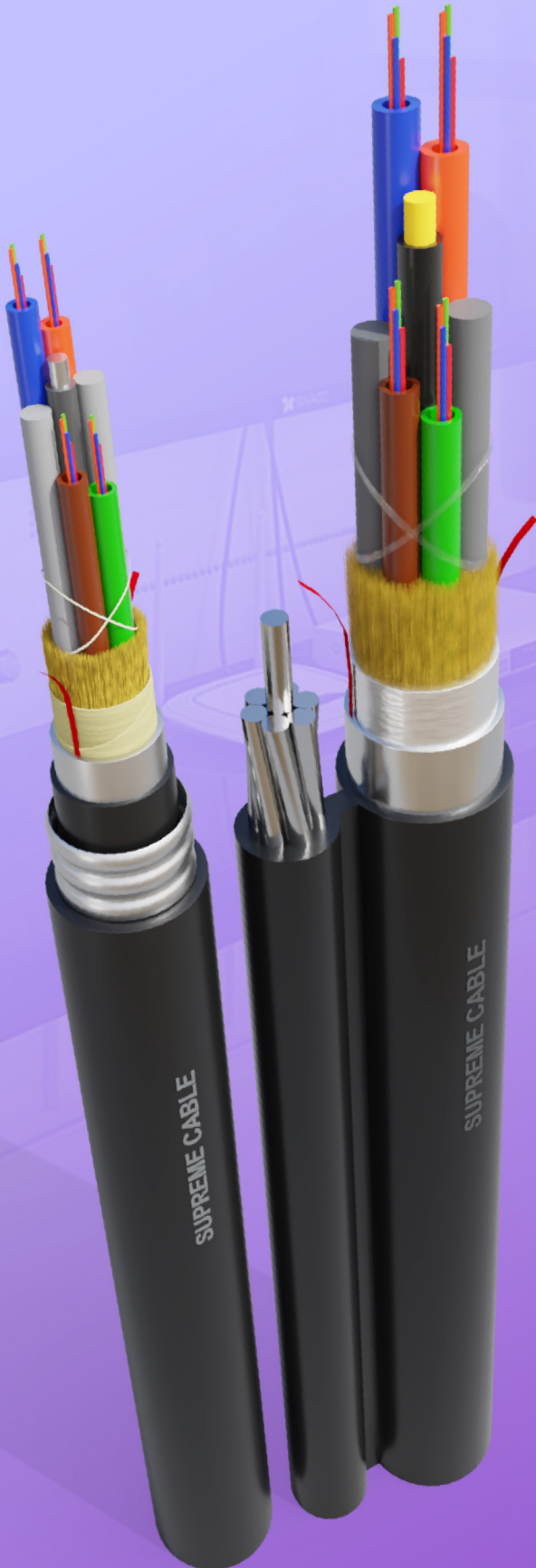

PT SUPREME CABLE

MANUFACTURING & COMMERCE Tbk.

(PT SUCACO Tbk.)



Product Catalogue
**OPTICAL
FIBER
CABLE**

www.sucaco.com

 @supreme_cable

 @supreme_cable

**QUALITY CABLE
YOU CAN TRUST**

Scan For
Catalogue





Company Background

Specializing in the cable business since 1970, PT SUPREME CABLE MANUFACTURING & COMMERCE Tbk. (PT SUCACO Tbk.) has grown steadily to become a largest and leading cable manufacturer, with international reputation for quality and reliability. Established in 1970, PT SUCACO Tbk. is a pioneer in the modern industry. With technical assistance from Furukawa Electric Co Ltd. Japan and International Executives Service Corp, USA, the company began commercial operations in 1972.

We produce and markets power cable up to 150 kV, optical and telecommunication cables, control cables, instrumentation cables, coaxial cables, fire resistant cable, airport lighting cable, aluminium bare over head conductors and enamelled wires under brand name of " SUPREME ". The Company is also involved through its affiliated companies, in various line of business. The company has a Quality Assurance Program and ISO 9001 certificate from SGS international certification body of quality management system, ISO 14001 for environment management system and ISO 18001 for safety management system. Today, PT SUCACO Tbk. has grown to become a reliable partner in infrastructures, buildings and various projects.



Your **Partner**
for **Quality & Reliability**



TABLE OF CONTENT	PAGE
1. Configuration	1
2. Basic Core & Features	2
3. Characteristic and Colouring	3
4. Single Mode Duct Optical Fiber Cable	5
5. Single Mode Direct Buried Optical Fiber Cable	6
6. Single Mode Aerial Optical Fiber Cable	7
7. Single Mode ADSS Optical Fiber Cable	8
8. Single Mode SCPT Duct Cable	9
9. Single Mode SCPT Aerial Cable	10
10. Indoor Optical Fiber Cable	11
11. Drop Aerial Optical Fiber Cable	12
12. Drop Optical Fiber Cable	13

CONFIGURATION

Fiber Selection



Fiber Colouring

Applying colour to identify fibers.



Fiber Encapsulation

Tubing of fibers thixotropic filling gel.



Stranding

Stranding around central strength member and adding the peripheral strength member (aramid yarn), water blocking tape, laminated aluminum polyethelene tape as required.

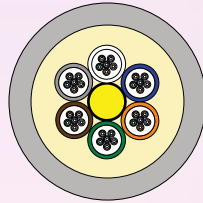

Sheathing

The outer sheath is chosen to meet the specific application. The sheath of the duct cable is applied directly to the core. For aerial applications a round steel messenger wire is added. Additional armour with outer sheath is applied for direct buried application.

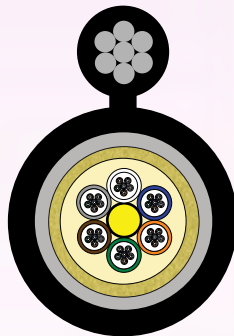

Fibers

Available in fiber counts from 4 to 264 wide variety of attenuation and bandwidth in both single mode and multi mode fibers.

Buffer Loose Tube Configuration



4 Fibers 6 Fibers 12 Fibers

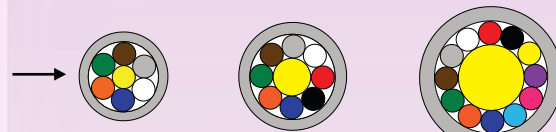

6 Tubes 8 Tubes 12 Tubes

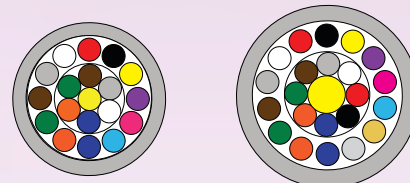

18 Tubes 22 Tubes

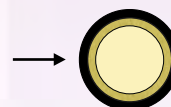

All-dielectric
Aramid Yarn
Polyethylene Sheath

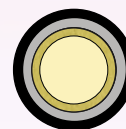

Light armour
Aramid Yarn
Polyethylene Sheath
Corrugated Steel Tape Armouring

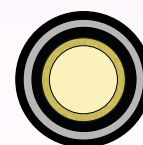

Single armour
Aramid Yarn
Two Polyethylene Sheath
Corrugated Steel tape Armouring

BASIC CORE & FEATURES

Environmental

Operation temperature	= 10°C ~ 50°C
Storage temperature	= 10°C ~ 70°C
Humidity operation temperature	= 20 % ~ 100 %
Humidity storage temperature	= 20 % ~ 95 %

Basic Core Design

- One or two layers thermal plastic elements stranded surrounding a central strength member. Elements can be either loose tubes or Polyethylene filler rods, depending on fibres count.
- Coloured thermal plastic tube containing 4, 6 or 12 fibres with water swellable compound or thixotropic gel filled.
- The tube are covered with a flooding compound and water swellable tape.

Features of Optical Fiber Cable

- Wide bandwidth.
Suitable for high speed, wide band, large capacity telecommunication lines. It can transmit large amounts of information and have excellent characteristics such as low loss and wide bandwidth.
- Freedom from Electromagnetic Interference.
Optical fibers are not affected by strong electromagnetic interference originating from power cables, railway and radio waves. They do not emit unwanted radiation and crosstalk between fibres exists.
- Small diameter and light weight.
Multi fiber optical cables have a small diameter and are light weight and flexible. Optical Fiber Cable are permit effective utilization of spaces and can also be applicable to long distance use are easier to handle and install than conventional metal cables.
- Strong to withstand the normal installation forces of strain, crush, bend and twist.
- Optical fiber cables can be used to great advantage in all fields of telecommunication, including telecommunication data transmission and control systems in buildings, factories and power station, signal transmission system between computers, ITV/CATV signal transmission currents, telecommunication control systems in electric power stations and along railway, control and alarms systems, chemical plants and as wiring aircrafts, automobiles, ships and trains.
- High quality optical fiber provides good transmission performance.
- Accurate fiber excess length control ensures excellent mechanical and temperature performance.
- Special gel filled loose tube provides perfect optical fiber protection.

CHARACTERISTICS AND COLOURING

Fiber and Loose Tube Colouring

Fiber/ Loose tube number	1	2	3	4	5	6	7	8	9	10	11	12	13	14
Fiber colour	Blue	Orange	Green	Brown	Grey	White	Red	Black	Yellow	Violet	Pink	Turquoise		
Loose tube colour														
Inner layer	Blue	Orange	Green	Brown	Grey	White	Red	Black	Yellow	Violet	Pink	Turquoise		
Outer layer	Blue	Orange	Green	Brown	Grey	White	Red	Black	Yellow	Violet	Pink	Turquoise	Gold	Silver

Optical Characteristics

Properties	Unit	Value		
		G 652 D	G 655 C	
			Large Effective Area	Reduce Slope
Cladding diameter	µm	125 ± 1	125 ± 1	125.0 ± 1
Cladding non-circularity	%	≤ 1.0	≤ 2.0	≤ 2.0
Core /Cladding concentricity error	µm	≤ 0.6	≤ 0.8	≤ 0.8
Coating diameter	µm	250 ± 15	250 ± 15	250 ± 15
Mode Field Diameter :	µm			
• 1,310 nm		9.2 ± 0.4	-	-
• 1,550 nm		-	9.6 ± 0.4	8.6 ± 0.4
Cable cut-off wavelength	nm	≤ 1,260	≤ 1,450	≤ 1,450
Attenuation coefficient :	dB/km			
• 1,310 nm ~ 1,625 nm		≤ 0.35	-	-
• 1,380 nm ~ 1,386 nm		≤ 0.35	-	-
• 1,550 nm		≤ 0.215	≤ 0.215	≤ 0.215
• 1,625 nm		-	≤ 0.30	≤ 0.30
Macrobend loss :	dB			
• 1,625 nm radius = 30 mm, 100 turns		≤ 0.10	≤ 0.1	≤ 0.05
Chromatic dispersion :				
• Wavelength	nm	1,300 ~ 1,324	1,530 ~ 1,565	1,530 ~ 1,565
• Zero dispersion slope	ps/nm ² .km	≤ 0.092	-	-
• D _{min}	ps/nm.km	-	1,0	2,0
• D _{max}	ps/nm.km	-	10	6,0
• D _{max} - D _{min}	ps/nm.km	-	≤ 5.0	-
PMD coefficient	ps/√km	≤ 0.10	≤ 0.10	≤ 0.10
Proof stress level	Gpa	≥ 0.69	≥ 0.69	≥ 0.69

Optical Characteristics

Properties	Unit	Value	
		G 657 A	G 657 B
Cladding diameter	µm	125 ± 0.7	125 ± 0.7
Cladding non-circularity	%	≤ 1.0	≤ 1.0
Core /Cladding concentricity error	µm	≤ 0.5	≤ 0.5
Coating diameter	µm	250 ± 15	250 ± 15
Mode Field Diameter : • 1,310 nm	µm	9.6 ± 0.4	8.6 ± 0.4
Cable cut-off wavelength	nm	≤ 1,260	≤ 1,260
Attenuation coefficient : • 1,310 nm ~ 1,625 nm • 1,380 nm ~ 1,386 nm • 1,550 nm	dB/km	≤ 0.35 ≤ 0.35 ≤ 0.215	≤ 0.35 ≤ 0.35 ≤ 0.215
Macrobend loss : • 1,550 nm radius = 15 mm, 10 turns radius = 10 mm, 1 turns radius = 7,5 mm, 1 turns	dB	- - -	≤ 0.03 ≤ 0.1 ≤ 0.5
• 1,625 nm radius = 15 mm, 10 turns radius = 10 mm, 1 turns radius = 7,5 mm, 1 turns		≤ 0.10 ≤ 0.20 -	≤ 0.1 ≤ 0.2 ≤ 1.0
Chromatic dispersion : • Wavelength • Zero dispersion slope	nm ps/nm ² .km	1,300 ~ 1,324 ≤ 0.092	- -
PMD coefficient	ps/√km	≤ 0.10	≤ 0.10
Proof stress level	Gpa	≥ 0.69	≥ 0.69

Duct Cable

Single Mode Loose Tube Optical Fiber (STEL K-015)

Colour coded optical fibers, strength members, gel filled loose tube, water swellable tape, aluminium tape screened and polyethylene sheath.

Application

Designed to be pulled into duct system or laid into duct tray in service ducts of an Optical Fiber Cable communications network.

Construction

- 1 Single mode colour coded optical fibers
- 2 Thixotropic filling gel
- 3 Extruded colour coded loose tubes
- 4 Fiber reinforced plastic with polyethylene sheath or round steel wire with polyethylene sheath
- 5 Filler rods
- 6 Binder
- 7 Jelly filled interstices
- 8 Aramid yarn
- 9 Water swellable tape
- 10 Rip cord
- 11 Aluminium tape
- 12 Polyethylene outer sheath

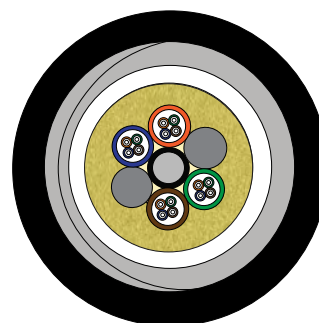
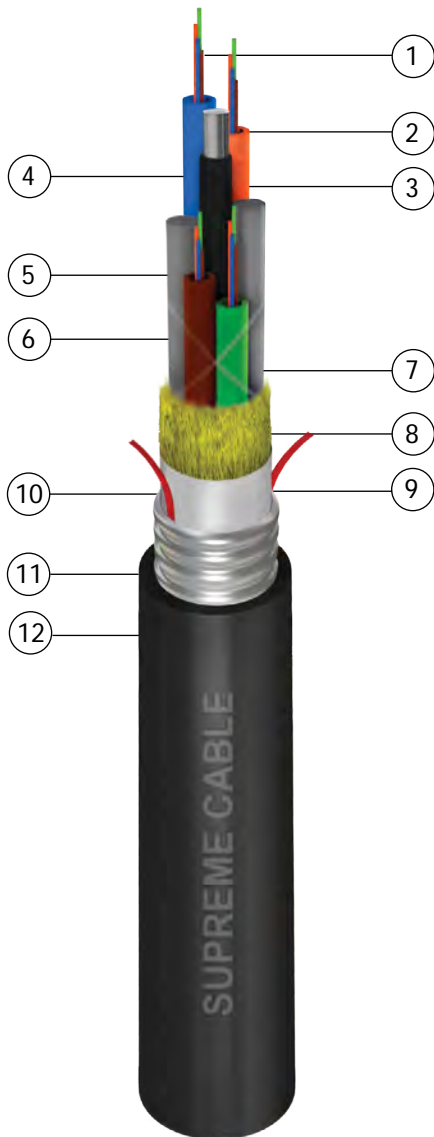

Structure and Technical Specification

Loose tube					Cable		Strength member
Number of inner layer (pcs)	Number of outer layer (pcs)	Number of fiber (cores)	Inner diameter minimum (mm)	Thickness minimum (mm)	Outer diameter maximum (mm)	Total of fiber (cores)	Diameter (mm)
6	-	4	1.2	0,35	13.0	4 - 16	2,5 ± 0,1
6	-	6	1.2	0,35	14.0	6 - 36	2,5 ± 0,1
6	-	12	1.7	0,40	17.0	24 - 72	2,8 ± 0,1
8	-	12	1.7	0,40	18.0	60 - 96	4,5 ± 0,1
6	4	12	1.7	0,40	22.0	120	2,5 ± 0,1
6	6	12	1.7	0,40	22.0	144	2,5 ± 0,1
6	12	12	1.7	0,40	22.0	216	2,8 ± 0,1
12	-	12	1.7	0,40	22.0	120 - 144	8,0 ± 0,1
8	12	12	1.7	0,40	22.0	240	4,5 ± 0,1
8	14	12	1.7	0,40	24.0	264	4,5 ± 0,1

Direct Buried Cable Single Mode Loose Tube Optical Fiber (STEL K-016)

Colour coded optical fibers, strength members, gel filled loose tube, water swellable tape, aluminium tape screened, steel tape corrugated armoured and polyethylene sheath.

Application

Designed to be buried directly in the ground by either trenching or ploughing.

Construction

- 1 Single mode colour coded optical fibers
- 2 Thixotropic filling gel
- 3 Extruded colour coded loose tubes
- 4 Fiber reinforced plastic with polyethylene sheath or round steel wire with polyethylene sheath
- 5 Filler rods
- 6 Binder
- 7 Jelly filled interstices
- 8 Aramid yarns
- 9 Water swellable tape
- 10 Rip cord
- 11 Aluminium tape
- 12 Polyethylene inner sheath
- 13 Corrugated steel tape
- 14 Polyethylene outer sheath

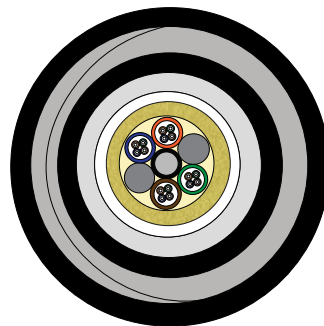
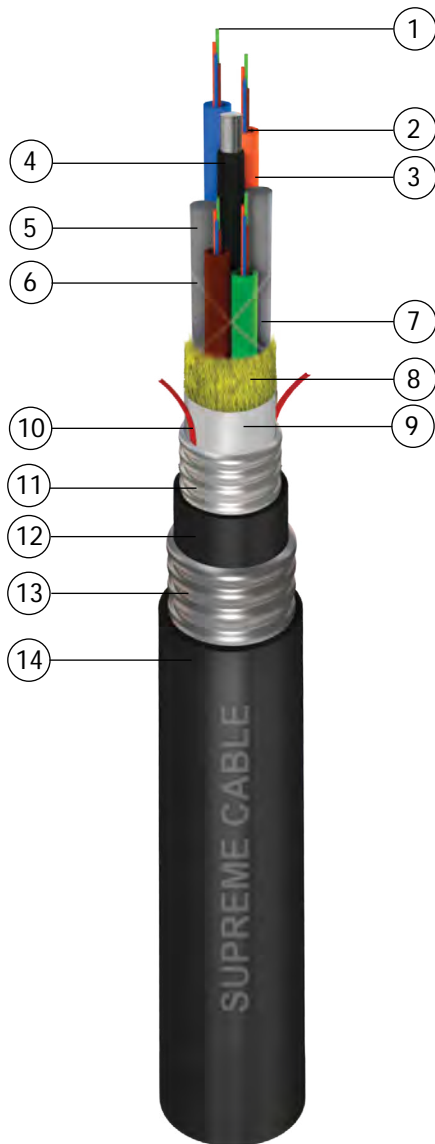

Structure and Technical Specification

Loose tube					Cable		Strength member
Number of inner layer (pcs)	Number of outer layer (pcs)	Number of fiber (cores)	Inner diameter minimum (mm)	Thickness minimum (mm)	Outer diameter maximum (mm)	Total of fiber (cores)	Diameter (mm)
6	-	4	1.2	0,35	21.2	4 - 16	2,5 ± 0,1
6	-	6	1.2	0,35	22.2	6 - 36	2,5 ± 0,1
6	-	12	1.7	0,40	25.2	24 - 72	2,8 ± 0,1
8	-	12	1.7	0,40	26.2	60 - 96	4,5 ± 0,1
6	4	12	1.7	0,40	30.2	120	2,5 ± 0,1
6	6	12	1.7	0,40	30.2	144	2,5 ± 0,1
6	12	12	1.7	0,40	30.2	216	2,8 ± 0,1
12	-	12	1.7	0,40	30.2	120 - 144	8,0 ± 0,1
8	12	12	1.7	0,40	30.2	240	4,5 ± 0,1
8	14	12	1.7	0,40	32.2	264	4,5 ± 0,1

Aerial Cable Single Mode Loose Tube Optical Fiber (STEL K-017)

Colour coded optical fibers, strength members, gel filled loose tube, water swellable tape, aluminium tape screened, steel wire messenger and polyethylene sheath.

Application

Designed to be hung from the utility poles of an Optical Fiber Cable communications network.

Construction

- 1 Single mode colour coded optical fibers
- 2 Thixotropic filling gel
- 3 Extruded colour coded loose tubes
- 4 Fiber reinforced plastic with polyethylene sheath
- 5 Filler rods
- 6 Binder
- 7 Jelly filled interstices
- 8 Aramid yarn
- 9 Water swellable tape
- 10 Rip cord
- 11 Aluminium tape
- 12 Stranded galvanized round steel wire messenger
- 13 Polyethylene outer sheath

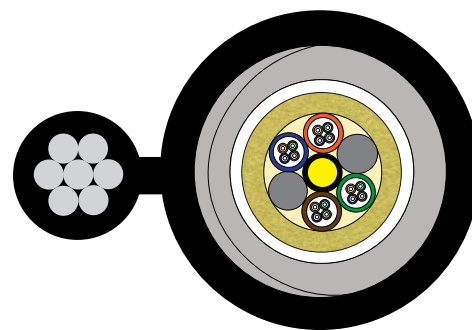
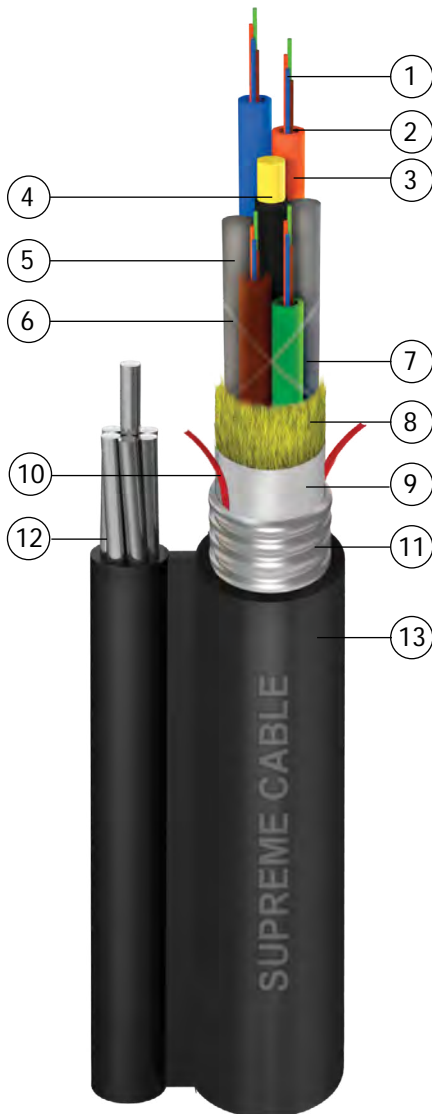

Structure and Technical Specification

Loose tube				Cable		Strength member
Number of inner layer (pcs)	Number of outer layer (pcs)	Inner diameter minimum (mm)	Thickness minimum (mm)	Outer diameter maximum (mm)	Total of fiber (cores)	Diameter (mm)
6	4	1.2	0,35	13.0	4 - 16	2,5 ± 0,1
6	6	1.2	0,35	14.0	6 - 36	2,5 ± 0,1
6	12	1.7	0,40	17.0	24 - 72	2,8 ± 0,1
8	12	1.7	0,40	18.0	60 - 96	4,5 ± 0,1

All Dielectric Self Supporting Aerial (ADSS) Cable

Single Mode Loose Tube ADSS Optical Fiber

Colour coded optical fibers, strength members, gel filled loose tube, water swellable tape, polyethylene inner sheath, aramid yarns and polyethylene sheath.

Application

Designed to be hung from the utility poles of an Optical Fiber Cable communications network.

Construction

- 1 Single mode colour coded optical fibers
- 2 Thixotropic filling gel
- 3 Thermal plastic colour coded tubes
- 4 Fiber reinforced plastic with polyethylene sheath
- 5 Filler rods
- 6 Binder
- 7 Polyethylene inner sheath (Optional)
- 8 Aramid yarns strength member
- 9 Rip cord
- 10 Polyethylene outer sheath

Main features

- o All dielectric structure, light weight, easy installation, excellent electromagnetic interference resistant and suitable for operating in electrical system or frequency lighting area.
- o All section water swellable present reliable performance of moisture proof and water impermeable.
- o High Young's Modulus for fiber reinforced plastic (FRP) as central strength member high breaking load.

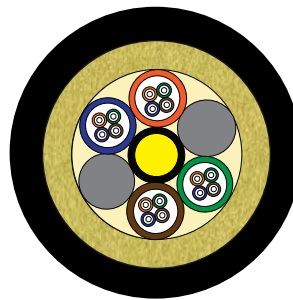
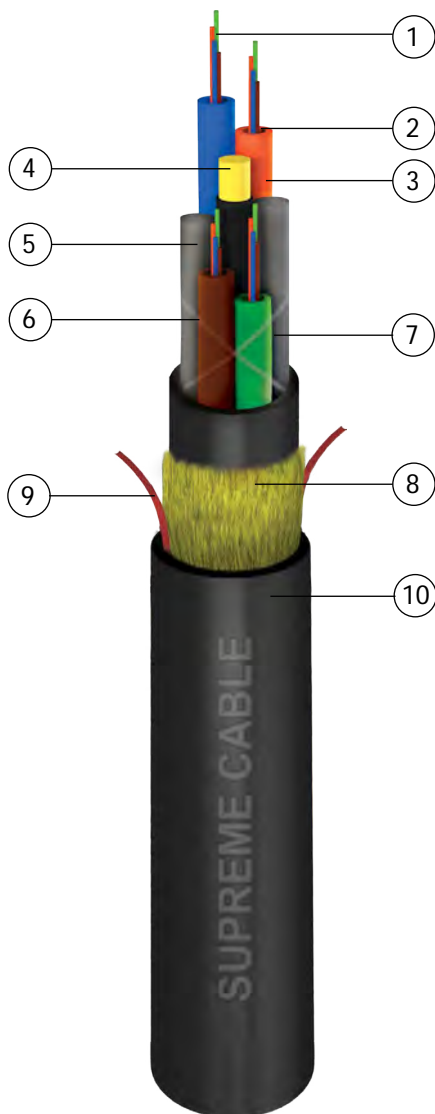

Structure and Technical Specification

Total of fiber (cores)	Number of loose tube (pcs)	Number of fiber per Loose tube (cores)
2 ~ 36	6	6
38 ~ 72	6	12
74 ~ 96	8	12
98 ~ 120	10	12
122 ~ 144	12	12
146 ~ 216	18	12
≥ 216	Available upon customer's request	

Duct Cable Single Core Per Tube (SCPT) (STEL K-037)

Colour coded optical fibers, strength members, gel filled loose tube, water swellable tape, aluminium tape screened, and polyethylene sheath

Application

Designed to be pulled in to duct system or laid in to duct tray in service ducts of an Optical Fiber Cable Communications network.

Construction

- 1 Single mode colour coded optical fibers
- 2 Thixotropic filling gel
- 3 Extruded colour coded loose tubes
- 4 Round steel wire with polyethylene sheath
- 5 Aramid yarns
- 6 Water swellable tape
- 7 Rip cord
- 8 Aluminium tape
- 9 Polyethylene outer sheath

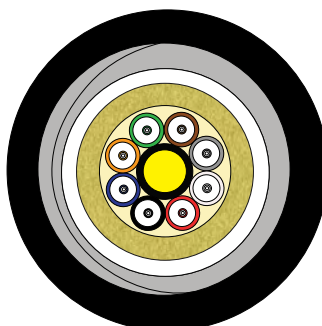
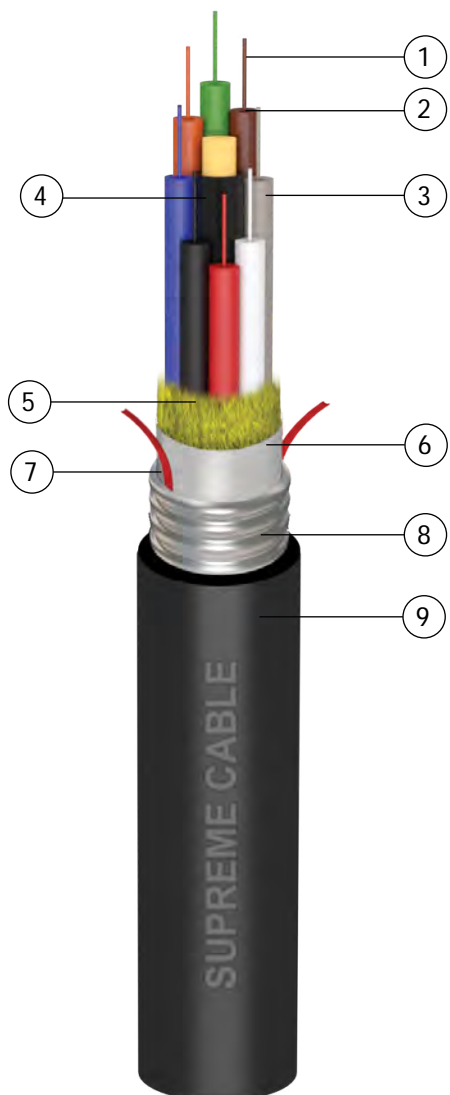

Structure and Technical Specification

Loose tube			Cable		Strength member
Number (pcs)	Diameter (mm)	Thickness (mm)	Outer diameter maximum (mm)	Total of fiber (cores)	Diameter (mm)
8	1,2	0,3	10,6	8	2,5 ± 0,1
10	1,2	0,3	11,6	10	3,5 ± 0,1
12	1,2	0,3	12,5	12	4,2 ± 0,1
18	1,2	0,3	13,5	18	1,8 ± 0,1
24	1,2	0,3	15,0	24	3,0 ± 0,1

Aerial Cable Single Core Per Tube (SCPT) (STEL K-036)

Colour coded optical fibers, strength members, gel filled loose tube, water swellable tape, aluminium tape screened, steel wire messenger and polyethylene sheath

Application

Designed to be hung from the utility poles of an Optical Fiber Cable communications network

Construction

- 1 Single mode colour coded optical fibers
- 2 Thixotropic filling gel
- 3 Extruded colour coded loose tubes
- 4 Fiber reinforced plastic with polyethylene sheath
- 5 Aramid yarn
- 6 Water swellable tape
- 7 Rip cord
- 8 Aluminium tape
- 9 Stranded galvanized round steel wire messenger
- 10 Polyethylene outer sheath

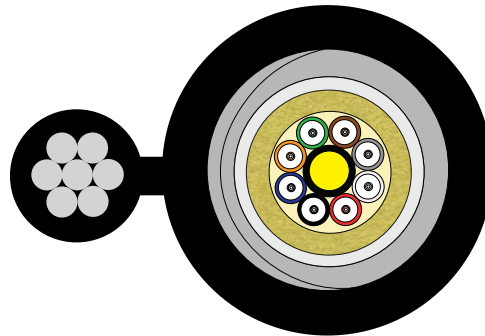
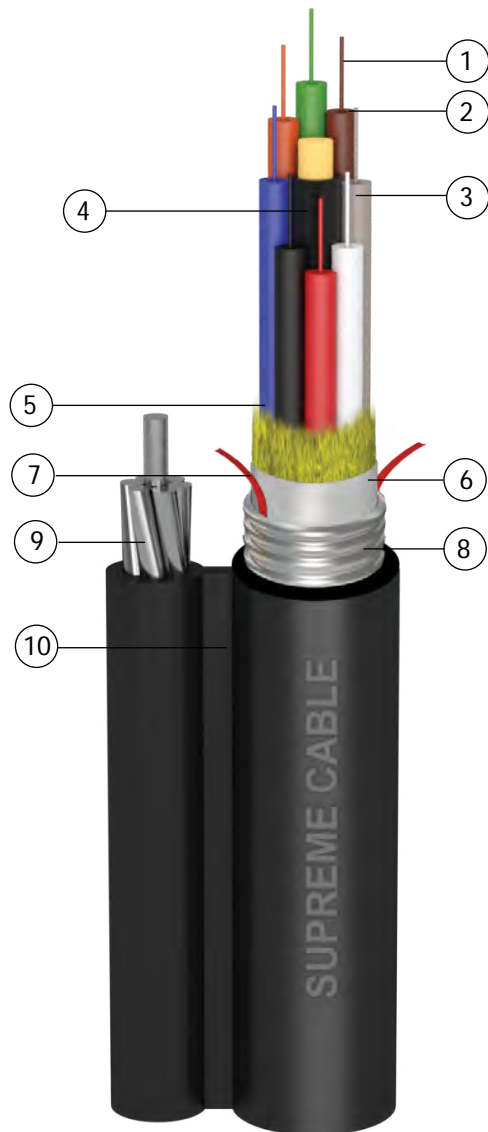

Structure and Technical Specification

Loose tube			Cable		Strength member
Number (pcs)	Diameter (mm)	Thickness (mm)	Outer diameter maximum (mm)	Total of fiber (cores)	Diameter (mm)
8	1,2	0,3	10,6	8	2,5 ± 0,1
10	1,2	0,3	11,6	10	3,5 ± 0,1
12	1,2	0,3	12,5	12	4,2 ± 0,1
18	1,2	0,3	13,5	18	1,8 ± 0,1
24	1,2	0,3	15,0	24	3,0 ± 0,1

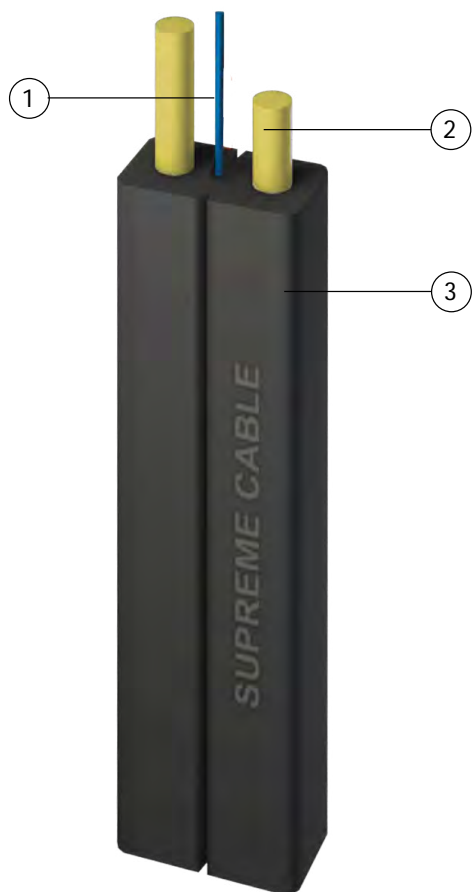

Indoor Optical Fiber Cable (STEL K-032)

Colour coded optical fibers, fiber reinforced plastic strength member and polyethylene sheath.

Application

Designed to be used in pipe as indoor optical fiber cable.

Construction

- 1 Fiber reinforced plastic with polyethylene sheath
- 2 Colour coded optical fibers
- 3 Polyethylene outer sheath

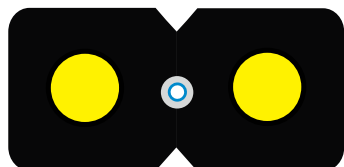

Fiber colouring

Fiber number (cores)	1	2
Colouring	Blue	Orange

Structure and Technical Specification

Total of fiber (cores)	Maximum overall diameter (mm x mm)
1	2.5 x 3.5
2	2.5 x 3.5



Drop Aerial Optical Fiber Cable (STEL K-033)

Colour coded optical fibres, galvanized round steel wire messenger, fiber reinforced plastic strength member and polyethylene sheath.

Application

Designed to be used in air as drop aerial optical fiber cable.

Construction

- 1 Galvanized round steel wire messenger
- 2 Fiber Reinforced Plastic with polyethylene sheath
- 3 Colour coded optical fibers
- 4 Polyethylene outer sheath

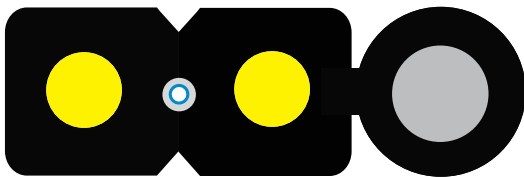

Fiber colouring

Fiber Number (cores)	1	2
Colouring	Blue	Orange

Structure and Technical Specification

Total of fiber (cores)	Nominal diameter of steel wire (mm)	Maximum overall diameter (mm x mm)
1	1.2	2.5 x 5.5
2	1.2	2.5 x 5.5



Drop Optical Fiber Cable (STEL K-034)

Colour coded optical fibers, fiber reinforced plastic strength member and polyethylene sheath.

Application

Designed to be used in pipe as drop optical fiber cable.

Construction

- 1 Fiber reinforced plastic with polyethylene sheath
- 2 Colour coded optical fibers
- 3 Polyethylene outer sheath

Fiber Colouring

Fiber number (cores)	1	2
Colouring	Blue	Orange

Structure and Technical Specification

Total of fiber (cores)	Maximum overall diameter (mm x mm)
1	2.5 x 3.5
2	2.5 x 3.5